

Section view A-A
Scale: 1:1

Detail D
Scale: 2:1

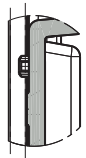

PCB space inside seal 81x 81mm

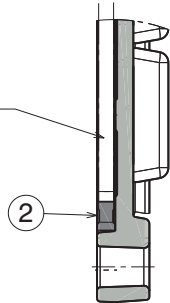

Detail B
Scale: 2:1



Detail C
Scale: 2:1

CS15911_STRADELLA-IP-28-T2-PC
COMPONENTS

INDEX	PART	TYPE	MATERIAL	COLOR / COATING
1	C15900_STRADELLA-28-SEAL		Silicone	
2	C15899_STRADELLA-28-T2		PC	clear

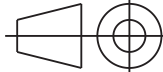
MECHANICAL DRAWING		FIRST ANGLE PROJECTION: 	This drawing is the property of LEDiL Oy. It may not be copied or otherwise distributed without prior written permission from LEDiL Oy.
PRODUCT	STRADELLA		
		WEIGHT	-
		A3	SHEET 1/2

LEDiL®

H G F E D C B A

4

3

2

1

4

3

2

1

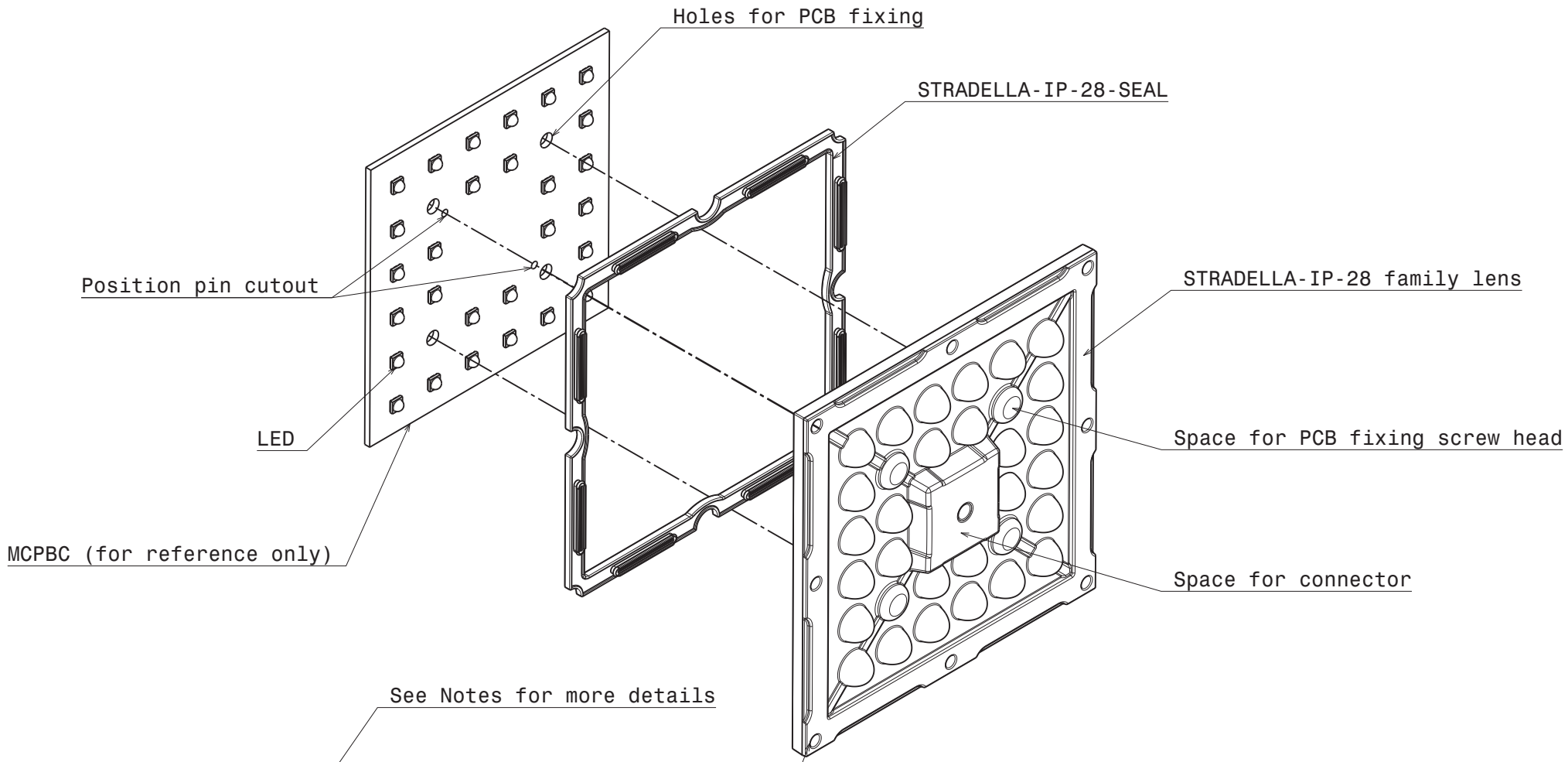

LENS fixing:
 8pcs M3 screw recommended for fixing
 Use washer with screw if possible
 Use maximum tightening torque of 0.60Nm
 Countersunk screws not allowed

MECHANICAL DRAWING		LEDiL [®]
PRODUCT STRADELLA-IP-28 family		
Plastic moulding general tolerances according to DIN 16901-130 and applies if not otherwise shown in the drawing. Silicone moulding general tolerances according to ISO 3302-1 Class M3 and applies if not otherwise shown in the drawing.	FIRST ANGLE PROJECTION: 	This drawing is the property of LEDiL Oy. It may not be copied or otherwise distributed without prior written permission from LEDiL Oy.
SCALE 1:1	WEIGHT -	
		A3 SHEET 2/2

@ A B A